

## THERMOSTATIC STEAM TRAPS AND AIR ELIMINATORS TH 32 Y – TH32Y/CK (DN ½” – 1” ; DN 15 – 25)

**DESCRIPTION**

The TH32Y series thermostatic steam traps and air eliminators are specifically designed for use on process equipment such as kettle cookers, sterilizers, food, chemical and laundry equipment.

Connections are female screwed or flanged.

**MAIN FEATURES**

Modulating discharge.

Discharges condensate close to steam temperature.

Thermostats for different sub cooling (5°K to 30°K).

Excellent air discharge .

Operates on moderate superheated steam.

Built-in strainer.

**OPTIONS:** LC-low capacity  
Integral check valve  
Blowdown valve

**USE:** Saturated steam.

**AVAILABLE**

**MODELS:** TH32Y, TH32Y-CK (with check valve)

**SIZES:** DN ½” to 1” ; DN15 to DN25.

**CONNECTIONS:** Female screwed ISO 7/1 Rp (BS21)

Flanged EN 1092-1 PN40 or ANSI

**INSTALLATION:** Horizontal installation recommended,  
can be installed in any position.

See IMI installation and maintenance instructions.



BODY LIMITING CONDITIONS		
FLANGED PN40 / ANSI 300 *	FLANGED ANSI 150 **	RELATED TEMP.
ALLOW. PRES.	ALLOW. PRES.	
40 bar	19,3 bar	50 °C
35 bar	15,8 bar	150 °C
30,4 bar	12,1 bar	250 °C
27,6 bar	10,2 bar	300 °C

PMO - Max. operating pressure 22 bar

TMO - Max. operating temperature 250 °C

\* According to EN1092-1:2007 ; \*\* Acc. to EN1759-1:2004

Body limiting conditions PN40 or below, depending on the type of connection adopted. Rating PN40 for thread, SW and BW.

FLOW RATE CAPACITY IN Kgs/h																
MODEL	SIZE	DIFFERENTIAL PRESSURE (bar)														
		0,2	0,3	0,5	1	1,5	2	3	4	6	8	10	13	15	20	22
TH32Y	15 - 25	70	120	140	255	330	385	455	510	600	670	700	720	750	775	795
TH32YLC	15 - 25	45	55	70	95	125	135	180	200	270	315	330	360	370	405	415

Capacities shown refer to condensate at 10°C below saturated steam temperature (standard type-S thermostat) .

Thermostats for 5° C type-H and 30° type-L, also available.

Capacities for cold condensate discharge at 20°C are two to three times greater.

DIMENSIONS (mm)											
Screwed and SW*						EN PN16/PN40		ANSI 150		ANSI 300	
SIZE DN	A	B	C	D	WGT. Kgs	E	WGT. Kgs	E	WGT. Kgs	E	WGT. Kgs
15-1/2"	95	59	95	65	1,6	150	3,2	150	2,7	150	3,5
20-3/4"	95	59	95	65	1,6	150	3,9	150	3,1	150	4,7
25-1"	95	65	95	65	1,8	160	4,7	160	4,3	160	5,9

\* BW (butt weld) on request.

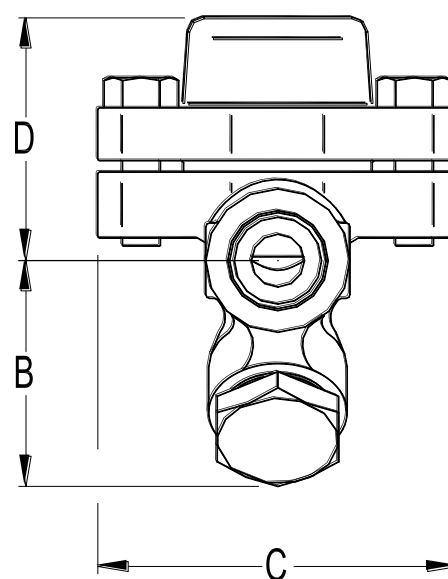
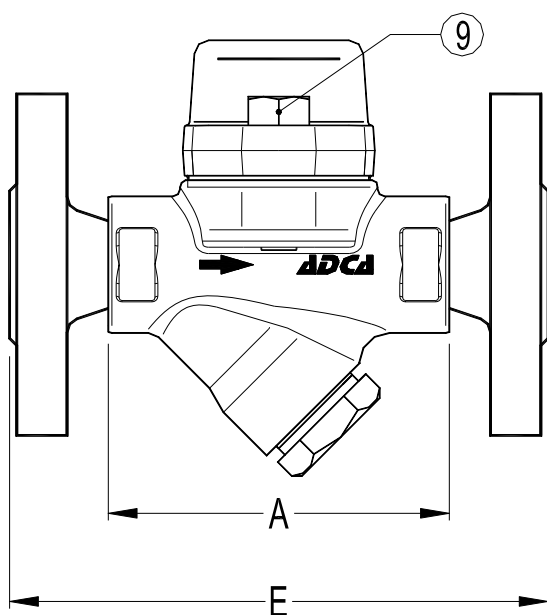

MATERIALS		
POS.N r.	DESIGNATION	MATERIAL
1	Body	P250GH / 1.0460
2	Cover	P250GH / 1.0460
3	* Gasket	St.St./Graphite
4	* Valve seat	AISI304 / 1.4301
5	* Thermostatic element	Stainless steel
6	* Strainer screen	AISI304 / 1.4301
7	* Gasket	St.Steel / Graphite
8	Cover strainer	A 105 / 1.0432
9	Bolts	A2-70

\* Available spare parts

